

HFTR4BA

Transformer for Distributed Power Supply in IGBT Gate Drive

MECHANICAL DIMENSIONS

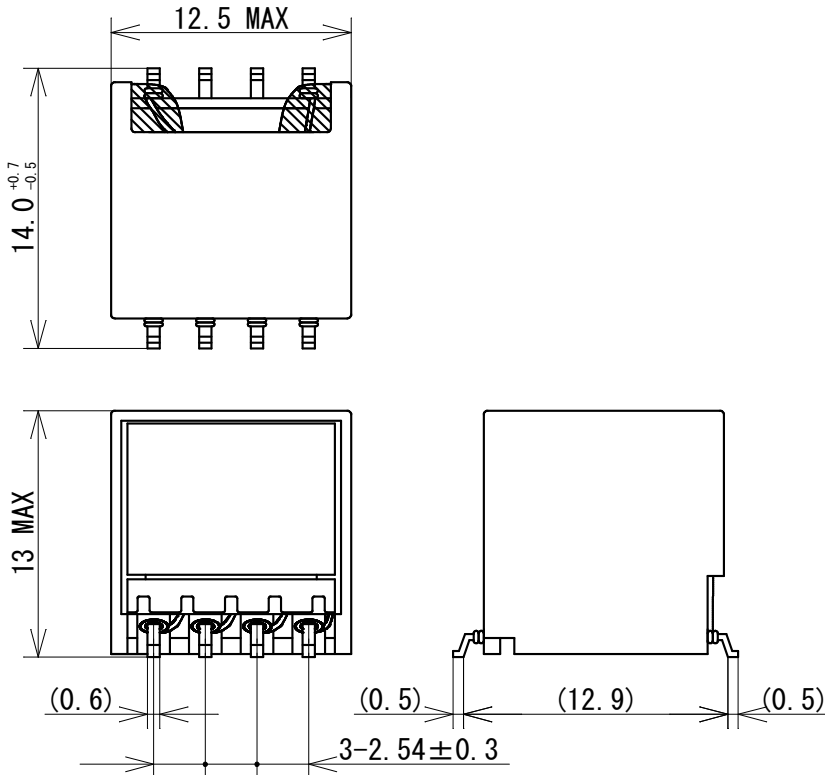

SCHEMATIC

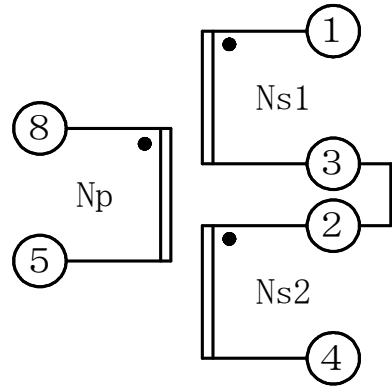

Turns Ratio
Np : Ns = 1 : 3.5

It is a premise to connect the second terminal to the third terminal on a printed circuit board.

Applicable Model : ACPL-33JT
(Frequency:150kHz).

Class B Equivalent(130°C)/UL105°C(Class A)

Withstand voltage : AC5.0kV

Creepage distance : 8mm(Np~Ns)

※Precautions for use

For transformers that have been manufactured for more than 6 months, please check the solder wettability of the terminals before use.

ELECTRICAL SPECIFICATIONS

Parameter	Pins Under Test	Test Conditions	STD TOLERANCE
INDUCTANCE	8 - 5	10kHz 1Vrms	7μHTyp.
	1 - 4	10kHz 1Vrms	(86μH)
DC RESISTANCE	8 - 5	T = 25°C	≤0.17Ω
DIELECTRIC STRENGTH	8:1	AC5.0kV 1MINUTE	
	8: CORE	AC5.0kV 1MINUTE	
	1: CORE	AC0.5kV 1MINUTE	

*The design might be changed according to the test outcome.