

SAMTM
Speedy Accuracy Maintainability

1480G
2480G series



Proposal for a new generation

SAMTM

Speedy Accuracy Maintainability

1480G **2480G series**



G series = Next Generation

mass flow controller



From the release of the first of our SFC480 series, SAM brand high-performance mass flow controllers continue in the tradition of perfection. High corrosion resistance and stable control performance are possible thanks to a waveform diaphragm made of a Ni-Co alloy (YET® 101), developed by Proterial. This technology demonstrates that Proterial is a manufacturer of high grade metallic materials. Proterial includes features like “dual-range” mass flow controller and a “hybrid” mass flow controller, thanks to the latest digital control technology developed for the SFC1480F series. Proterial products that are equipped with these technologies enjoy a well deserved reputation from globally recognized customers. Real SAM-brand products are highly valued as premium performance designs.

In an ever changing and demanding market for even more advanced mass flow controllers, Proterial is proud to introduce the G series. This design is positioned to play a major role in the next generation of controllers. This G series is an all-in-one mass flow controller that meets or exceeds the next generation of requirements, a step ahead of the competition. These advances are in response to our customers' needs for functions such as guaranteed control accuracy with actual gas, MG/MR, PI.

With SAM's advanced technologies, such as its reliable diaphragm valve structure, digital control, etc., the G series offers innovative features that can be used for a variety of new functions. Proterial is developing a product lineup that best meets user's needs, such as an all-in-one mass flow controller that includes all the functions along with models that include only desired functions.

The search for excellent technologies with unlimited investment is a bygone era. Today we seek appropriate technologies with appropriate levels of investment. We believe our new mass flow controller must apply the technologies which are desired to receive good marks from customers. Customers can get the most desirable functions in performance from one of our many G series models, at a cost to match the expectation of performance. If users have a mass flow controller problems, Proterial strongly recommends that close review of the G series will satisfy the demands for next generation semiconductor production.

neration

G series

The G series controllers are all-in-one mass flow controllers ready for the next generation of requirements for guaranteed accuracy with the actual gas, MG/MR, PI.

New functions in the G series

Multi-gas / multi-range (MG/MR) function

The G series has new functions which allow one mass flow controller to handle two or more gas types and ranges.

When mass flow controllers are equipped with this function the need for dedicated devices is reduced to only a few models which reduces the capital

investment and inventory liability.

Also, the G series MFCs provide a flow rate accuracy guarantee for the actual gas type, so that the performance (precision and response) of the MFC before changing the flow rate can be maintained after a change.

Pressure Insensitive (PI) function

While a mass flow controller is controlling the flow rate and another gas line is connected to the same gas source, the upstream gas supply pressure changes instantly which can cause the flow rate control to fluctuate by this change in pressure. This symptom comes from the fact that the mass flow controller tries to maintain control of the flow rate as it detects the change in pressure at the flow

rate sensor. To reduce or eliminate this problem, a line regulator for each gas line is installed to augment pressure fluctuation.

The PI function reduces this influence by sensing pressure changes with a pressure sensor incorporated in the device. This interrupts the feedback from the flow rate sensor to the control valve, and keeps the control valve opening at the optimum level.

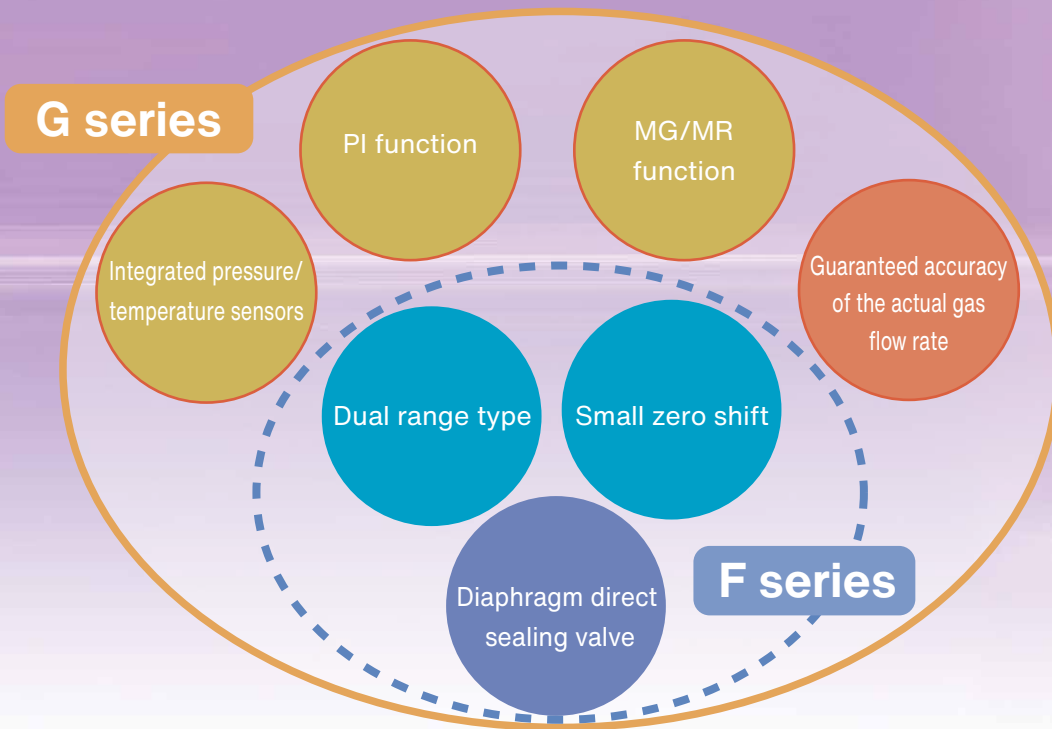

Table of models and functions

Model name	Function			<div style="border: 1px solid black; padding: 2px; margin-bottom: 5px;">Connection specifications</div> Wseal™ Cseal UJR	<div style="border: 1px solid black; padding: 2px; margin-bottom: 5px;">Communication specifications</div> RS232C RS485 DeviceNet™
	Standard	Optional			
	MG/MR function (Guaranteed accuracy with the actual gas)	PI function	LCD display unit		
1480FX 2480FX	*			<div style="border: 1px solid black; padding: 5px; width: fit-content; margin: 0 auto;">MG / MR</div>	
1480G1 2480G1	*	*	*	<div style="border: 1px solid black; padding: 5px; width: fit-content; margin: 0 auto;">MG / MR + PI</div>	

1480G1 / 2480G1 series

For both the 1.5" and 1.125" IGS™

PI Mass Flow Controllers



Dimensions

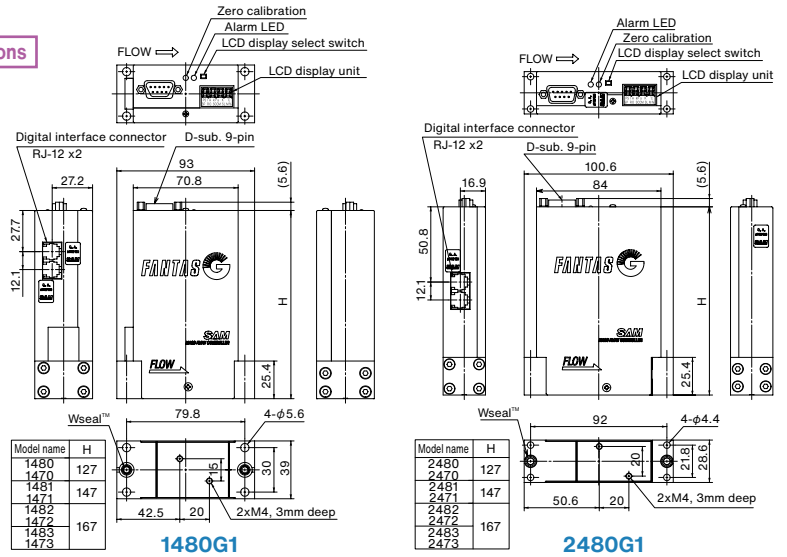

Item		Specifications *1			
Model name		1480G1 2480G1	1481G1 2481G1	1482G1 2482G1	1483G1 2483G1
Standard full scale flow rate (N ₂ equivalent)		2SCCM ~5,500SCCM	~11SLM	~30SLM	~50SLM
Function		1) Multi-gas/multi-range, 2) PI function, 3) LCD display (flow rate output, flow rate setting, pressure, and temperature)			
Valve operation		Normally closed / normally open			
Flow rate control range		2~100% F.S.			
Operation pressure *2	Inlet pressure	0.05~0.3 MPa (G) 7.3~43.5 PSI (G)		0.1~0.3 MPa (G) 14.5~43.5 PSI (G)	0.2~0.3 MPa (G) 29.0~43.5 PSI (G)
	Outlet pressure	Vacuum to ambient pressure			
Proof pressure		1.0 MPa(G) 145 PSI(G)			
Temperature	Operation	5~50 °C			
	Accuracy guaranteed	15~35 °C			
	Heating temperature when not powered	65 °C max			
Humidity		35~80%RH (non condensing)			
Installation position		Horizontal, Vertical	Horizontal, Vertical (option)		
Flow rate setting signal		0.1 - 5 VDC (absolute rating: Max. ±15 VDC)			
Flow rate output signal		0 - 5 VDC (maximum output: ±15 VDC) +15 VDC ±4%, 140 mA max -15 VDC ±4%, 140 mA max			
Required power					
Hardware	Material of gas wetted surface	Housing, flange, valve seat	SUS316L		
		Diaphragm	YET101 (Ni-Co alloy)		
		Flow sensor	SUS316L		Ni
		Seal *3	SUS316L		
	Pressure sensor	SUS316L			
Surface finish of components that contact the gas		Specially electro-polished (standard)			
Fitting		Wseal™, Cseal, 1/4" UJR male			
LCD display unit		4 digit display (6 x 4 mm), LED backlight			
External leakage standard		Max. 1x10 ⁻¹¹ Pa·m ³ /s (He)			
Flow rate control	Accuracy	N ₂ gas	10~100%	± (0.5% S.P. + 0.15% F.S.)	
			2~10%	±0.2% F.S.	
	Actual gas	10~100%	± (1.5% S.P. + 0.35% F.S.)		
		2~10%	±0.5% F.S.		
	Linearity	N ₂ gas	±0.3% F.S.		
		Actual gas	±1.0% F.S.		
	Repeatability	10~100%	± (0.1% S.P. + 0.05% F.S.)		
2~10%		±0.06% F.S.			
Flow rate sensor guaranteed zero point deviation range		±0.5% F.S. / year, max.			
Temperature dependence	Zero point		±0.01% F.S. / °C (15~35 °C)		
	Span		±0.01% S.P. / °C (15~35 °C)		
Response Time	0% → (20~100%)		Max. 1.0 sec. to reach ±2% S.P. of the set value.		
	0% → (2~20%)		Max. 1.5 sec. to reach ±0.4% S.P. of the set value.		
PI function *4	Flow rate fluctuation width during pressure variations	Pressure gradient: <0.5kPa 0.1PSI/0.12sec	±1.0% S.P.		
		Pressure gradient: <0.02MPa 2.9PSI	± (1.5% S.P. + 1.0% F.S.)		
	>0.5kPa 0.1PSI/0.12sec	Pressure fluctuation width 0.02~0.05MPa 2.9~7.3PSI	± (3.0% S.P. + 1.0% F.S.)		
Flow rate change time when the pressure changes		Within 1 second of the pressure fluctuation			
Pressure, temperature display	Pressure sensor	Pressure range	-99.9~999.9 kPa (G) -14.5~145 PSI (G)		
		Accuracy	±0.5% F.S.		
		Repeatability	±0.01% F.S.		
		Temperature dependence	0.05% / °C		
		Pressure output	LCD display and digital communication (no analog output)		
Temperature measuring range		273.2~323.2 K (0~50 °C)			

*1: The specifications above are guaranteed values when the MFC was measured by itself in standard conditions. The MFC may not meet the specifications above, depending on the measurement conditions.

*2: The 147*G1 / 247*G1 series are also available for use with minute pressure differences. Please inquire separately for the specifications of our minute pressure difference models.

*3: A model using a rubber seal is also available. Please inquire separately about the rubber seal specifications.

*4: The PI function may not perform as specified in certain plumbing conditions. Please consult us in advance.

What is a G1?

The G1 series is a line of mass flow controllers that are equipped with MG/MR and PI (Pressure Insensitive) functions.

The PI function is resistant to fluctuation in the actual flow rate caused by fluctuation in the inlet pressure of the mass flow controller (MFC).

An ordinary gas supply unit uses a regulator to absorb pressure fluctuation in the gas supply inlet, and to stabilize the actual flow rate.

Therefore, any current mass flow controller, without this regulator, is directly influenced by fluctuation in the gas supply inlet pressure, and the actual flow rate will change instantly by a large amount.

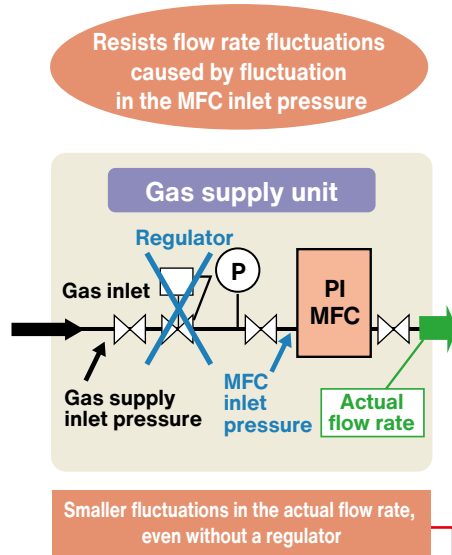

The PI function, without needing this regulator, restricts the influence of fluctuation in the gas supply inlet pressure, and greatly reduces fluctuation in the actual flow rate.

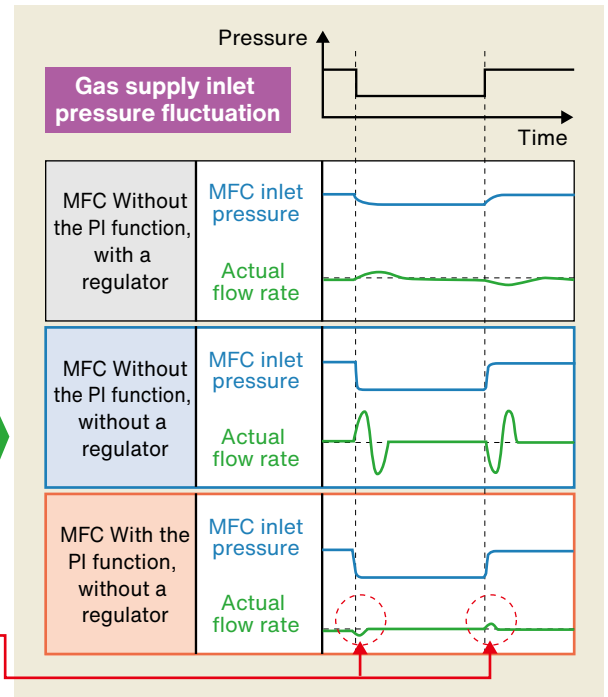

Principle of the PI control

At a normal stable pressure, a mass flow controller controls the flow rate using feedback control, in order to match the signal from the flow rate sensor with the setting.

The PI control stops this feedback when the integrated pressure sensor detects an inlet pressure fluctuation.

The pressure sensing circuit controls valve voltage

directly using this pressure signal, thereby reducing fluctuation in the flow rate. It controls the opening of the flow rate control valve directly.

In other words, a PI equipped mass flow controller uses two control methods: PI control when a pressure fluctuation occurs, and feedback control while the pressure is stable.

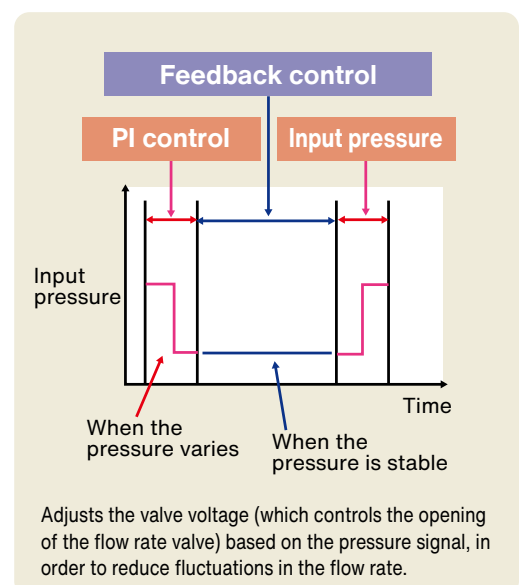
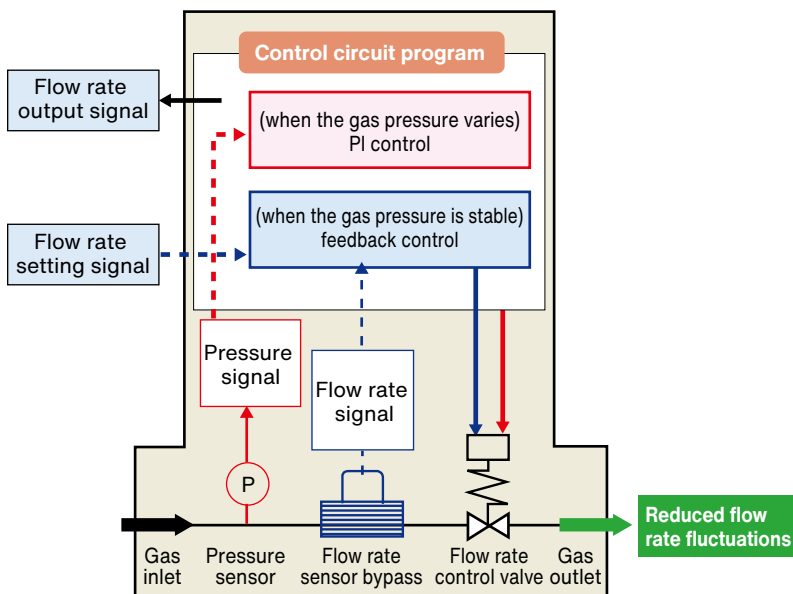

1480G1-D / 2480G1-D series

DeviceNet™ communication type For both the 1.5" and 1.125" IGST™

PI Mass Flow Controllers



Dimensions

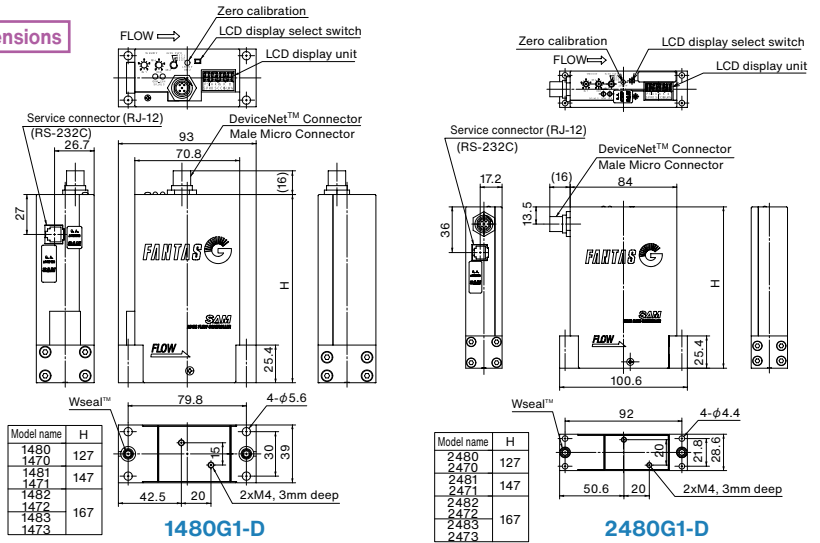

Item		Specifications *1			
Model name		1480G1-D0	1481G1-D0	1482G1-D0	1483G1-D0
Standard full scale flow rate (N ₂ equivalent)		2SCCM	11SLM	30SLM	50SLM
Function		1) Multi-gas/multi-range, 2) PI function, 3) LCD display (flow rate output, flow rate setting, pressure, and temperature)			
Valve operation		Normally closed / normally open			
Flow rate control range		2~100% F.S.			
Operation pressure *2	Inlet pressure	0.05~0.3 MPa (G) 7.3~43.5 PSI (G)		0.1~0.3 MPa (G) 14.5~43.5 PSI (G)	0.2~0.3 MPa (G) 29.0~43.5 PSI (G)
	Outlet pressure	Vacuum to ambient pressure			
Proof pressure		1.0 MPa(G) 145 PSI(G)			
Temperature	Operation	5~50 °C			
	Accuracy guaranteed	15~35 °C			
Heating temperature when not powered		65 °C max			
Humidity		35~80%RH (non condensing)			
Installation position		Horizontal, Vertical	Horizontal, Vertical (option)		
Flow rate setting signal		DeviceNet™ communication *3			
Flow rate output signal		DeviceNet™ communication *3			
Required power		+24 VDC, 0.3 A max			
Hardware	Housing, flange, valve seat		SUS316L		
	Diaphragm		YET101 (Ni-Co alloy)		
	Material of gas wetted surface	Flow sensor	SUS316L		Ni
		Seal *4	SUS316L		
	Pressure sensor		SUS316L		
Surface finish of components that contact the gas		Specially electro-polished (standard)			
Fitting		Wseal™, Cseal, 1/4" UJR male			
LCD display unit		4 digit display (6 x 4 mm), LED backlight			
External leakage standard		Max. 1x10 ⁻¹¹ Pa·m ³ /s (He)			
Flow rate control	Accuracy	N ₂ gas	10~100%	± (0.5% S.P. + 0.15% F.S.)	
		Actual gas	2~10%	±0.2% F.S.	
	Linearity	N ₂ gas	10~100%	±0.3% F.S.	
		Actual gas	2~10%	±1.0% F.S.	
	Repeatability	10~100%	± (0.1% S.P. + 0.05% F.S.)		
		2~10%	±0.06% F.S.		
Flow rate sensor guaranteed zero point deviation range		±0.5% F.S. / year, max.			
Temperature dependence	Zero point	±0.01% F.S. / °C (15~35 °C)			
	Span	±0.01% S.P. / °C (15~35 °C)			
Response Time	0% → (20~100%)	Max. 1.0 sec. to reach ±2% S.P. of the set value.			
	0% → (2~20%)	Max. 1.5 sec. to reach ±0.4% S.P. of the set value.			
PI function *5	Flow rate fluctuation width during pressure variations	Pressure gradient: <0.5kPa 0.1PSI/0.12sec	Pressure fluctuation width <0.02MPa 2.9PSI	± (1.5% S.P. + 1.0% F.S.)	
		Pressure gradient: >0.5kPa 0.1PSI /0.12sec	Pressure fluctuation width 0.02~0.05MPa 2.9~7.3PSI	± (3.0% S.P. + 1.0% F.S.)	
	Flow rate change time when the pressure changes		Within 1 second of the pressure fluctuation		
Pressure, temperature display	Pressure sensor	Pressure range	-99.9~999.9 kPa (G) 14.5~145 PSI (G)		
		Accuracy	±0.5% F.S.		
		Repeatability	±0.01% F.S.		
		Temperature dependence	0.05% / °C		
	Pressure output		LCD display and DeviceNet™ communication (not analog output)		
Temperature measuring range		273.2~323.2 K (0~50 °C)			

*1: The specifications above are guaranteed values when the MFC was measured by itself in our standard conditions. The MFC may not meet the specifications above, depending on the measurement conditions.

*2: The 147*G1-D / 247*G1-D series are also available for use with minute pressure differences. Please inquire separately for the specifications of our minute pressure difference models.

*3: For details about DeviceNet™ communication, see page 10.

*4: A model using a rubber seal is also available. Please inquire separately about the rubber seal specifications.

*5: The PI function may not perform its specifications depending on each plumbing condition. Please consult us in advance.

MG/MR (multi-gas/multi-range) function

This is the core technology that is included in all the G series models is the MG/MR (multi-gas / multi-range) function. In conventional mass flow controllers, one controller would only handle one type of gas and one full scale flow rate range. This means that customers needed to have a dedicated mass flow controller for each system, and for each process recipe. With the FX series flow rate controller equipped with the MG/MR function, you can have up to 14 user recipes (full scale ranges of 2 SCCM to 50 SLM) to match the intended flow range, and you can change the gas type and flow rate to match the actual gas you want to handle. When connected to a personal computer, the metering conditions can be changed instantly (See page 10).

Proterial actual gas flow rate accuracy warranty system backs up this MG/MR function. A conventional mass flow controller only guarantees the flow rate accuracy with N₂ gas. To get the

flow rate conditions for your actual gas using a conventional MFC, a conversion factor must be used as a coefficient to convert the flow rate.

The reference values for these coefficients have been based of a variety of values, including calculated values, actually measured values, and empirical values. And, these were merely guidelines or reference values with some gas types. Although the MG/MR function is included, if the gas data deviates from the characteristics of the actual gas, the mass flow controller cannot perform as its designed level.

With the G series mass flow controller, in addition to the flow rate reference for N₂ gas (that ensures conformance with the national standard using the conventional gravimetric method), we installed full scale actual gas metering and exhaust gas processing facilities at our factory. Using these facilities, measurement is made for each type of gas at each full-scale range, and record the data. This is then used as actual gas data.

Conceptual diagram of the MG/MR (multi-gas/multi-range) mass flow controller

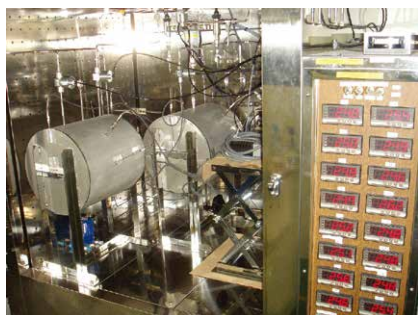
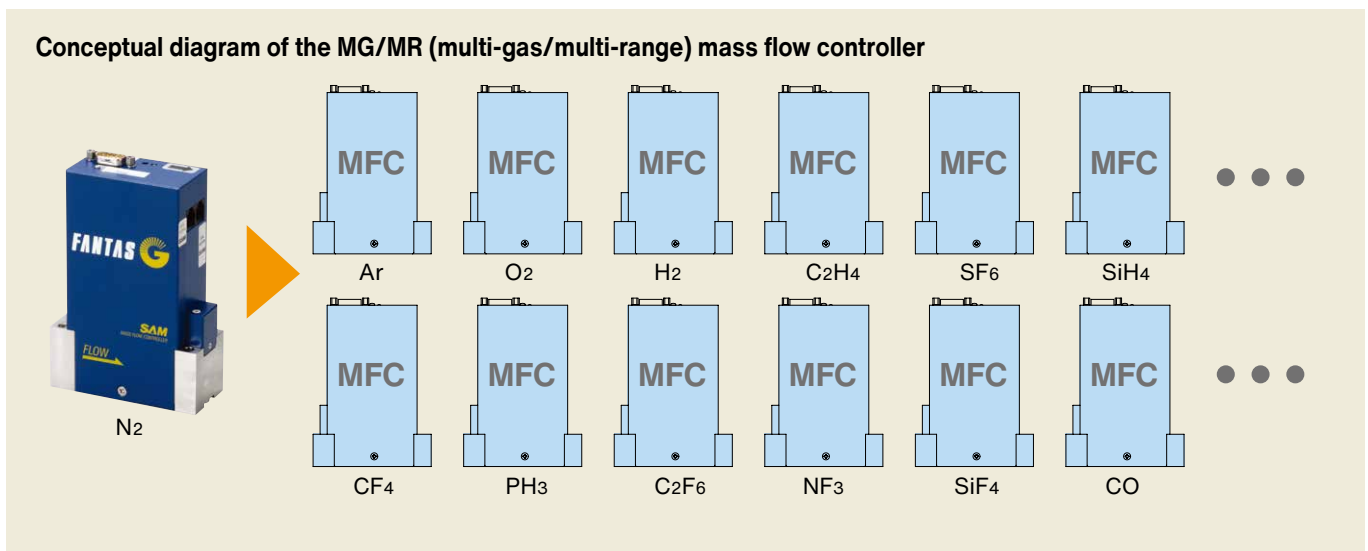

Actual gas flow rate measurement facility

Abbreviation	Standard full-scale flow rate range (N ₂ equivalent)
MG/MR	Flow range
FR-01	2~5 SCCM
FR-02	6~14 SCCM
FR-03	15~26 SCCM
FR-04	27~38 SCCM
FR-05	39~71 SCCM
FR-06	72~103 SCCM
FR-07	104~192 SCCM
FR-08	193~279 SCCM
FR-09	280~754 SCCM
FR-10	755~2036 SCCM
FR-11	2037~5500 SCCM
FR-12	5501~11000 SCCM
FR-13	11001~30000 SCCM
FR-14	30001~50000 SCCM

How to use the MG/MR conversion program

Gas type and flow rate can be converting using an MG/MR conversion program. Connect the mass flow controller to a personal computer using a digital communication cable, and use our proprietary program. One can convert the data easily with a simple GUI interface program. Following the program instructions, first select the gas type, and then flow rate units. A flow rate range will appear, and it can be changed. Enter a flow rate value and the setting is complete.

Users can change the gas type and flow rate.

<MG/MR conversion program> Select the correction amount data according to the gas type and flow rate you want to control

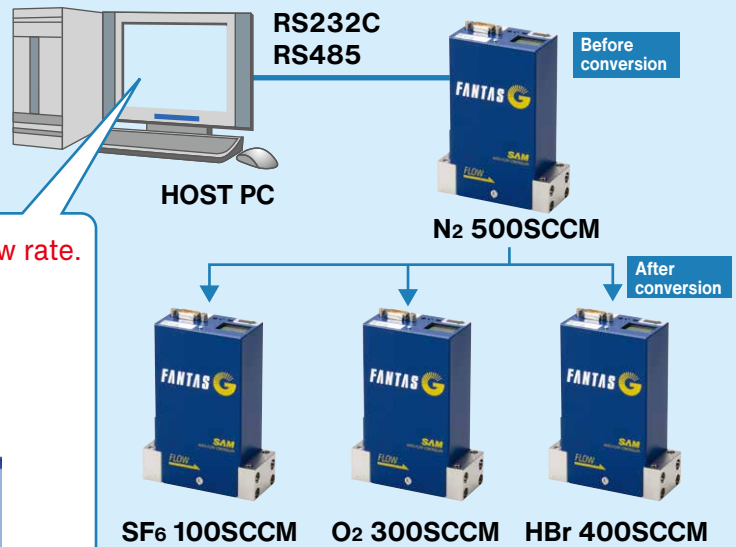

Simple operation to set the gas type and flow rate.

Select a gas type

The flow rate range is displayed (user settable).

Enter a flow rate

A screen that shows the program is converting.

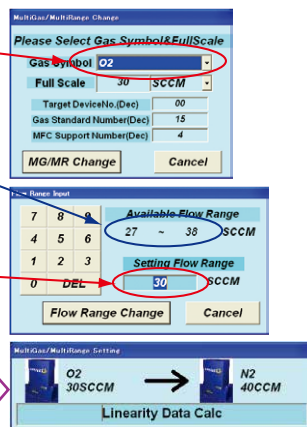

* For details about the operation, see the instruction manual

Models compatible with the DeviceNet™ communication system

About DeviceNet™

This is a field network recognized world wide, and it is approved as a standard sensor bus by the SEMI.

Field devices can be connected using serial communication in place of an I/O connection, allowing transfer of a large volume of data effectively.

The DeviceNet™ specifications are administrated by the ODVA (ODVA, Inc.) a non-profit body established to promote the spread of this system world-wide.

What are the advantages of employing DeviceNet™

- 1) By using serial communication from an I/O connection, one does not need an AD / DA / O board which can decrease configuration and set up costs.
- 2) Only network cables are needed and this reduces cabling costs, which decreases required man-hours, shortening engineering periods, and avoids problems from incorrect wiring.
- 3) DeviceNet™ employs a CAN (Controller Area Network) as a communication controller, and you can use a variety of CAN error detection functions.
- 4) The DeviceNet™ specifications are administrated by the ODVA, and have been normalized as international standards by IEC and SEMI. With this normalization, they are completely open, and lots of control devices are available from multiple vendors. You can choose the optimum device for your application.
- 5) The power for DeviceNet™ is only +24 VDC. You do not need to supply ± 15 VDC for the mass flow controller.

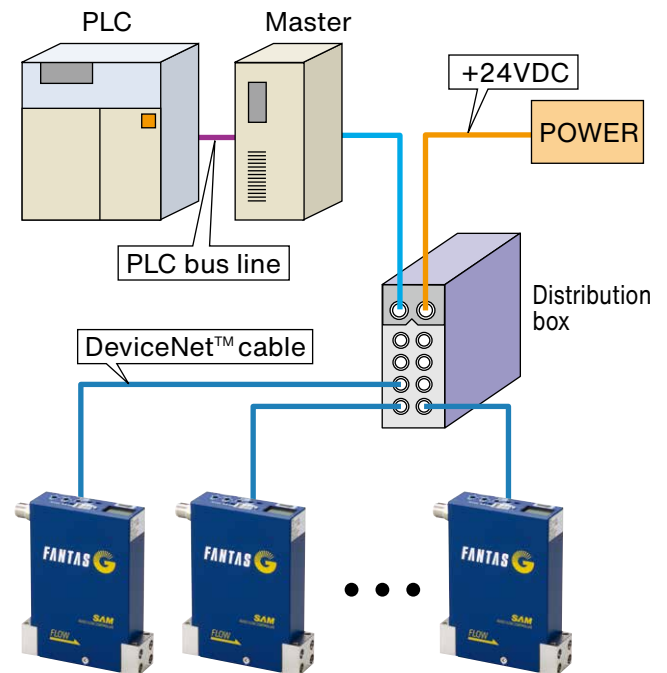

Communication connector pin assignment

Analog interface connector (D-Sub 9-pin)

Connector used : D-Subminiature, 9-pin connector (M3 screw)

Compatible plug : 17JE-13090-02 (D8B) (made by DDK) or equivalent

1) Connector model : L type

Pin number	Function
1	Valve open/close input (+15 VDC = Fully open; -15 VDC = Fully closed)
2	Output (0 to 5 VDC)
3	+15 VDC
4	COM (± 15 VDC)
5	-15 VDC
6	Input (0.1 to 5 VDC)
7	COM (output)
8	COM (Input)
9	Valve voltage (0 to 5VDC)

2) Connector model: Q type

Pin number	Function
1	Valve Full open (operate by connecting to COM)
2	Out put (0 to 5 VDC)
3	+15 VDC
4	COM (± 15 VDC)
5	-15 VDC
6	Input (0.1 to 5 VDC)
7	COM (output)
8	COM (Input)
9	Valve Full-close (operate by connecting to COM)

Digital interface connector

Connector used : 43814-6621 (made by Molex) (RJ-12 x 2 connectors)

Pin number	Signal name	
	RS232C	RS485
1	COM (Signal)	
2	No Connection	
3	Rxd	RS-
4	Txd	RS+
5	N.C.	
6	N.C.	

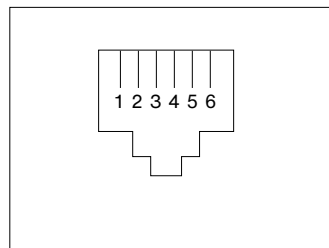

Note 1 : Rxd, Txd: RS232C Input and output

Note 2 : RS-, RS+: RS480 Input and output

DeviceNet™ connector

Connector used : DeviceNet™ Male Micro Connector (CM02-8DR5P(D5) made by DDK, or equivalent)

Pin number	Signal name
1	Drain
2	V+
3	V-
4	CAN_H
5	CAN_L

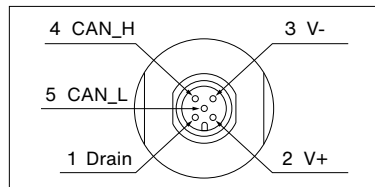

Additional functions

Function name	Description	Setting and reading methods
Alarm function	See the item for the alarm function	By command
Flow sensor zero reset function	Reset the flow sensor zero	By command or when the switch on the top is pressed
Pressure sensor zero reset function	Reset the pressure sensor zero	By command
Pressure sensor span correction function	Correct the pressure sensor span	By command
Lamp response function	Control the flow rate using a specified time for the step flow rate setting.	By command
Flow control valve voltage monitor output function	Set the flow control valve opening (0 to 5 VDC)	By command or analog voltage output (only L type)
Flow control valve fully open / close function	Open and close the flow control valve completely	By command, ± 15 VDC, or contact point connection

Alarm function

Alarm cause	Alarm LED display	Alarm output condition
Normal operation	Green LED blinks at 1 Hz	No alarm
Flow rate setting does not the match flow rate output	Red LED lights	The mis-match between the flow rate setting and the flow rate output is 10% or more of the full scale and has continued for 10 seconds or longer
Abnormal ± 15 VDC power supply	Turns off	The ± 15 VDC power supply is outside the range of ± 12 VDC to ± 17 VDC, and has been for 0.5 seconds or longer.
EEPROM access error	Red LED lights	Abnormal value in the EEPROM data.
Digital communication error	Red LED goes on	Did not receive a normal digital command
Change in flow rate control status (Change from the preset status)	Red LED blinks at 2 Hz	The change in the preset value was 10% or more of the full scale and continued for 10 seconds or longer. Or, the cumulative value of the zero point correction amount for the flow sensor is more than $\pm 20\%$ of full scale
<ul style="list-style-type: none"> ·Flow rate setting changed ·Flow rate output changed ·Flow control valve open level changed ·Abnormal zero point correction value for the flow sensor 		



Precautions to ensure safe use

In order to use our products safely, make sure to read the relevant instruction manuals before use.

1480G, 2480G series ordering information

Model name						
Size	Temperature	Pressure	Flow range	Series	Seal	Operation
1	4	8	0	G1	M	C
1	1.5" size					
2	1.125" size					
	4	Normal temperature type				
		8	Normal pressure type			
		7	Low inlet pressure type			
			0	2~5,500 SCCM (FR-01~11)		
			1	11 SLM (FR-12)		
			2	30 SLM (FR-13)		
			3	50 SLM (FR-14)		
			G1	Multi gas, multi range, Pressure insensitive		
				M	Metal seal	
				R	Rubber seal	
					C	Normally closed
					O	Normally open

Optional code			
Fitting	Connector	Flow sensor material	Option
UG	L	N	
4V *	1/4" UJR male, 124mm		
UG	1.5" W seal, 1.125" Wseal™		
AG	1.5" C seal, 1.125" C seal		
	L0	D-sub 9-pin (top mount), valve open/close signal ±15 VDC type	
	Q0	D-sub 9-pin (top mount), valve open/close signal COM connection type	
	T0 **	D-sub 9-pin (upstream mount), digital output type	
	D0	DeviceNet™	
	Blank	Ni free	
	N	Ni sensor	
		Blank	None
		-	For details, please contact us.

Note: * Can be used with a 1/4" UJR male, 124mm.

** Only the 24** series can be used with a T0 connector.

SAM™·FANTAS®·YET®101 is a registered trademark of Proterial, Ltd.

Proterial, Ltd.

<https://www.proterial.com/e>

Headquarters

Piping Components Business Unit
Fine Flow Dept.

Toyosu Prime Square, 5-6-36 Toyosu, Koto-ku, Tokyo 135-0061, Japan
Tel +81-(0)50-3664-9511 Fax +81-294-87-7147

- The contents of this catalog are correct as of Jan 2024.
- The specification, appearance, etc. of products listed in this pamphlet may be changed without prior notice.
- Due to printing reasons, the product colors in this pamphlet may be different from the actual product colors.
- This catalog is copyright 2007 by Proterial, Ltd. all rights reserved. Duplication of any part of the contents without prior written approval is strictly prohibited.
- If you have questions about anything described in this pamphlet, please contact the address shown on the left.
- **SAM** is a trademark of Proterial, Ltd.
- IGS™ and Wseal™ are registered trademarks of Fujikin Incorporated.
- DeviceNet™ is a registered trademark of ODVA, Inc.
- We are not liable for and do not accept responsibility for any loss, direct or indirect, caused by incorrect use, careless handling, force majeure, war, terrorism, fire, pollution, use in unapproved environments, salt damage, or any natural disasters (such as wind or flood damage, earthquakes or lightning), or for any consequential damage.